

TENDER NO: UCSSL/CC/T/CIVIL/298 DT: 06-11-2024

**TENDER FOR CONSTRUCTION OF STRUCTURAL
FOUNDATION FOR FIXING OF RAILS**

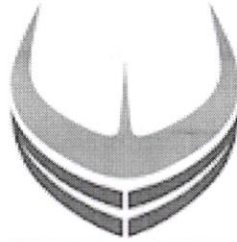

UDUPI COCHIN SHIPYARD LIMITED

**UDUPI COCHIN SHIPYARD LIMITED
MALPE, UDUPI 576108**





UDUPI COCHIN SHIPYARD LIMITED
Tender for Construction of Structural Foundation for Fixing of Rails
UCSL/CC/T/CIVIL/298 DT: 06TH NOVEMBER 2024

TENDER NOTICE

Tender No. & date	UCSL/CC/T/CIVIL/298 DT: 06 TH NOVEMBER 2024
Name of work	CONSTRUCTION OF STRUCTURAL FOUNDATION FOR FIXING OF RAILS AT UCSL MALPE FACILITIES.
Site Visit	09TH To 13TH NOVEMBER 2024
Last date & time of receipt of tender	15TH NOVEMBER 2024 (FRIDAY), 15:30HRS
Date & time of opening of Technical Bid (Part-I)	15TH NOVEMBER 2024 (FRIDAY), 15:30HRS

1. Password protected quotations in the prescribed form is invited from bidders for the work specified above, subject to the terms and conditions as mentioned in the annexure to the tender enquiry so as to reach the undersigned by email or through postal mode, as mentioned on or before the date and time as stipulated.

2. The following shall be submitted along with the quote: -

PART- I: TECHNICAL BID

- a. **Tender document duly signed on all pages** - Including Terms & conditions and Scope of work placed at Annexure I.
- b. **The Techno commercial Check List** at Annexure V to be filled up completely and duly signed.
- c. Duly filled form at Annexure – II & III.
- d. **Unpriced Price bid** (Price bid without price and marked as “QUOTED”) to be submitted along with Part-I.

PART-II: PRICE BID

- a. The price bids shall be prepared based on the price bid format at Annexure IV.

3. **Mode of Submission of Quote:**

- i. Bid shall be submitted as **Password Protected Zip File** in two parts.
Part I: Technical Bid – with all enclosures and annexures as mentioned in Para 2 above
Part II: Price Bid.
- ii. The files are to be forwarded as Two (2) separate password protected Zip files to **contractcell@udupicsl.com**

iii. **Part I and Part II are to be protected with separate and distinctly different passwords.**





UDUPI COCHIN SHIPYARD LIMITED

Tender for Construction of Structural Foundation for Fixing of Rails
UCSL/CC/T/CIVIL/298 DT: 06TH NOVEMBER 2024

- iv. The Bids will be opened on online mode during which the bidder will be advised to share the password through SMS with which the technical bid will be opened.
 - v. The price bids will be opened after technical evaluation and **only the technically qualified bidders will be invited for opening of price bids** which shall also be conducted on online mode as below.
 - vi. The bidders can also attend the bid opening physically at Udupi Cochin Shipyard Limited, Baputhotta Ware house complex Office, Udupi, Karnataka.
 - vii. The contractors can also submit the quotations in sealed covers (Two-Bid) – as separate sealed covers for Technical Bid and Price bid, both enclosed in a common sealed cover to reach the below mentioned address before the stipulated time.
4. The bidders shall ensure the receipt of bids at contractcell@udupicsl.com An acknowledgement mail shall be sent to the bidders on receipt of bids. UCSL takes no responsibility for delay, loss or non-receipt of tenders by mail by the stipulated time.
 5. The tender should be addressed to the **Assistant General Manager (Materials & Contract Cell), Udupi Cochin Shipyard Limited, Malpe Harbor Complex, Malpe, Udupi-576 108, Karnataka, India.**
 6. No deviations on the tender conditions will be accepted, and bids with deviations will be considered technically disqualified. The acceptance of a tender or part thereof will rest with the Assistant General Manager (Materials & Contract Cell), Udupi Cochin Shipyard Limited and reserves the authority to reject the tender received without assigning any reason.
 7. Contact Person: Mr. GIRISHA (U&M Dept) Ph No: +91 9986 977 749,
Mr. SARUN BABU E B (Contract Cell), Ph. No: +91 8592 048 487.

Assistant General Manager (Materials & Contract Cell)

सोणि क्लेमेन्ट टी एम
SONY CLEMENT T M
सहायक महापबंधक/ASSISTANT GENERAL MANAGER
उडुपि कोचीन शिपयार्ड लिमिटेड
UDUPI COCHIN SHIPYARD LIMITED
माल्पे, कर्नाटक/MALPE, KARNATAKA-576 108





UDUPI COCHIN SHIPYARD LIMITED

Tender for Construction of Structural Foundation for Fixing of Rails
UCSL/CC/T/CIVIL/298 DT: 06TH NOVEMBER 2024

TERMS AND CONDITIONS

TENDER FOR CONSTRUCTION OF STRUCTURAL FOUNDATION FOR FIXING OF RAILS

1. DESCRIPTION OF WORK

- 1.1. This tender pertains to the awarding of Construction of Civil structural foundation for fixing of rails for movable shed in repair bat at **Udupi Cochin Shipyard Limited (UCSL)**, Malpe Facility, Karnataka.
- 1.2. Movable shed size: Length 12 meters x Width 18 Meters x Height 15 Meters
- 1.3. Reference Documents (Drawing and Bill of Materials) RS0776S013A3R00
- 1.4. The Agencies are advised to familiarize themselves with the site conditions before quoting.
- 1.5. Bidders are requested to obtain clarifications, if any, and carefully study the documents and the scope of work of Contractor and UCSL, before submitting/ Finalizing their offer.

2. MINIMUM QUALIFICATION CRITERIA FOR PARTICIPATING IN THE TENDER WILL BE AS FOLLOWS:

- 2.1. The contractor shall have successfully completed of at least two works in last 5 years from the date of issue of tender document. The value of each work should not be less than Rs. 15 lakhs. Satisfactory completion certificate from the Client for work done should be submitted along with bid. For ongoing work, relevant certification from client shall be submitted along with copy of Purchase Order.

Or

The contractor shall have successfully completed of at least three works in last 5 years from the date of issue of tender document. The value of each work should not be less than Rs. 10 lakhs. Satisfactory completion certificate from the Client for work done should be submitted along with bid. For ongoing work, relevant certification from client shall be submitted along with copy of Purchase Order.

- 2.2. The Annual Turnover of the contractor should be more than Rs. 30 Lakhs in each financial year for the last three preceding years. (Audited Balance sheets showing turnover, Profit & Loss account of the firm for the preceding 03 years (2020-21, 2021-22, 2022-23) should be submitted along with the application for prequalification).
- 2.3. Offers from joint ventures/consortium will not be accepted.
- 2.4. Bidder shall not be under a declaration of ineligibility issued by Govt. of India/ State govt./ Public Sector Undertakings etc. The bidder shall not have been debarred / black listed by UCSL or by any of the Public Sector Undertaking or Government department etc.

3. METHOD OF AWARDING CONTRACT

- 3.1. Contract will be concluded with Bidder qualifying technically (including eligibility criteria), agreeing to Commercial conditions (Annexure V) and emerging as L1.
- 3.2. UCSL also reserves the right to split the work orders to any number of bidders willing to match with L1 rate, if the performance of selected bidder is not satisfactory.
- 3.3. UCSL reserves the right to cancel the tender if required.





UDUPI COCHIN SHIPYARD LIMITED

Tender for Construction of Structural Foundation for Fixing of Rails
UCSL/CC/T/CIVIL/298 DT: 06TH NOVEMBER 2024

4. SCOPE OF WORK

- 4.1. Dismantling R.C.C. concrete flooring including breaking concrete by chiseling, wedging etc. including cutting the reinforcement, stacking the serviceable materials and the debris separately upto a distance of 50 meter and shifting all the debris outside UCSL premises, excluding the reinforcements etc., complete.
- 4.2. Earthwork excavation in all soils including hard soils but excluding soft rock and hard rock, for foundations of walls, steps, footings, rafts, plinth beams, Cess pits, and in trenches including filling back. Excavation upto 1m depth, and stacking/ shifting the soil upto 500m or as directed by the engineer in charge.
- 4.3. Providing and laying 150mm downsize soling including hand packing, filling the interstices with sand, spalls and binding with Sand, watering, compacting by hand ramming using pointed end Downwards, as directed by the engineer in charge.
- 4.4. Earth work filling to the foundation and basement with available approved earth or red soil from external sources at contractor's cost (free from external materials) including watering and compacting in layers of 150mm thk with all lead and lift as directed by the engineer in charge.
- 4.5. Providing and laying P.C.C bed in M15 grade as levelling course using 40mm and down size graded crushed aggregate including compaction all materials, labour, curing etc. complete, as directed by the engineer in charge.
- 4.6. Providing and laying RCC in M30 (Only Ready Mixed Concrete with proper Design mix test reports) for the following works using 20mm and down size graded crushed aggregate including providing and fixing necessary scaffolding, machine mixing, compacting by mechanical vibrators, curing, hacking the surface etc., complete. Rate shall be the exclusive of the cost of steel reinforcement but inclusive of shuttering works. Concrete shall conform to relevant specifications of IS456 latest edition, as directed by the engineer in charge.
- 4.7. Fabrication and placing in position TMT reinforcement bars conforming to IS 1786- latest edition grade Fe 550 having elongation more than 14.5% or Fe 550D as per detailed reinforcement drawing and specifications including cutting, bending and tying with double 18 SWG binding wire complete. The rate shall be applicable for all heights and depths. Payment shall be made as per reinforcement drawings and with theoretical weights only including all authorized laps and hooks, as directed by the engineer in charge.
- 4.8. Fixing of Mild Steel Base plates, all as per the drawings, specification and directed by Engineer in charge. (350x25thk, 16mm dia Reinforcement Bent bar)
- 4.9. Fixing of Insert plates, all as per the drawings, specification and directed by Engineer in charge. (300x300x16thk, 4 Nos of ISA50x50x6 per IP, 300L)
- 4.10. Mobilization of entire labour / Workmanship (Skilled/Semiskilled/Unskilled) required for the construction of the movable shed in accordance with the specifications and drawings provided by UCSL.
- 4.11. Project Execution, supervision, management, and reporting of all the tasks/activities associated with the construction of the shed as above.
- 4.12. Ensuring best housekeeping practices to keep the work premises neat and clean



UDUPI COCHIN SHIPYARD LIMITED

Tender for Construction of Structural Foundation for Fixing of Rails
UCSL/CC/T/CIVIL/298 DT: 06TH NOVEMBER 2024

SCOPE OF THE CONTRACTOR ALSO INCLUDES:

- 4.13. Collection, Transportation/unloading of base plates supplied by UCSL from UCSL Hangarakkatte facility to the work site at Malpe facility.
- 4.14. Fixing of all the base plates and insert plates as per the drawing in proper line and level and welding to the foundation reinforcement. All the consumables will be under contractor's scope.
- 4.15. Maintaining the required Dimensional accuracy and surface finish as per UCSL Standards.
- 4.16. Providing all personnel protective items like safety helmets, gloves, welding shields, goggles, leg guards, safety belts, aprons, safety shoes, etc. to their employees.

5. SCOPE OF UCSL

- 5.1. Supply of all the base plates cut into required dimensions.
- 5.2. Providing the required applicable drawings with BOQ.
- 5.3. Materials as specified in the drawing for fixing in the foundation (i.e. steel plates) shall be supplied by UCSL.
- 5.4. Supply of electricity and water while construction at the UCSL site shall be provided by UCSL.
- 5.5. Crane/Hydra at UCSL premises will be provided by UCSL.

6. INDICATIVE QUANTUM OF WORK WITH BOQ
**INDICATIVE SCOPE OF WORK WITH BILL OF QUANTITIES AND SPECIFICATIONS
FOR CIVIL STRUCTURAL FOUNDATION FOR FIXING RAILS**

SL NO	Work Description	Nos	Length	Width	Height	Quantity	UOM
1	Concrete chipping						
	Dismantling R.C.C. concrete flooring including breaking concrete by chiseling, wedging etc. including cutting the reinforcement, stacking the serviceable materials and the debris separately upto a distance of 50metre and shifting all the debris outside UCSL premises, excluding the reinforcements etc., complete						
	RCC flooring	1	68.50	2.00	0.20	27.40	
		1	36.00	2.00	0.20	14.40	
						41.80	Cu.m
2	Excavation						
	Earthwork excavation in all soils including hard soils but excluding soft rock and hard rock, for foundations of walls, steps, footings, rafts, plinth beams, cess pits, and in trenches including filling back. Excavation upto 1m depth, and stacking/ shifting the soil upto 500m or as directed by the engineer in charge.						
		2	68.50	2.00	1.00	274.00	
						274.00	Cu.m



UDUPI COCHIN SHIPYARD LIMITED

Tender for Construction of Structural Foundation for Fixing of Rails
UCSL/CC/T/CIVIL/298 DT: 06TH NOVEMBER 2024

3	Soling						
	Providing and laying 150mm downsize soling including hand packing, filling the interstices with sand, spalls and binding with Sand, watering, compacting by hand ramming using pointed end Downwards, as directed by the engineer in charge.						
		2	68.50	2.00	0.23	63.02	
						63.02	Cu.m
4	Earth filling						
	Earth work filling to the foundation and basement with available approved earth or red soil from external sources at contractors cost (free from external materials) including watering and compacting in layers of 150mm thk with all lead and lift as directed by the engineer in charge.						
		2	68.50	0.80	0.60	65.76	
						65.76	Cu.m
5	PCC (M15)						
	Providing and laying P.C.C bed in M15 grade as levelling course using 40mm and down size graded crushed aggregate including compaction all materials, labour, curing etc complete, as directed by the engineer in charge.						
		2	68.50	2.00	0.10	27.40	
						27.40	Cu.m
6	RCC (M30)						
	Providing and laying RCC in M30 (Only Ready Mixed Concrete with proper Design mix test reports) for the following works using 20mm and down size graded crushed aggregate including providing and fixing necessary scaffolding, machine mixing, compacting by mechanical vibrators, curing, hacking the surface etc., complete. Rate shall be the exclusive of the cost of steel reinforcement but inclusive of shuttering works. Concrete shall conform to relevant specifications of IS456 latest edition, as directed by the engineer in charge.						
	RCC foundation	2	68.50	1.20	0.60	98.64	
	RCC foundation beam	2	68.50	0.45	0.30	18.50	
	RCC floor	2	68.50	0.80	0.20	21.92	
						139.06	Cu.m
7	REINFORCEMENT						
	Providing, Fabrication and placing in position TMT reinforcement bars conforming to IS 1786-latest edition grade Fe 550 having elongation more than 14.5% or Fe 550D as per detailed reinforcement drawing and specifications including cutting, bending and tying with double 18 SWG binding wire complete. The rate shall be applicable for all heights and depths. Payment shall be made as per reinforcement drawings and with theoretical weights only including all authorized laps and hooks, as directed by the engineer in-charge.					12800	KG
8	BASEPLATE (Supply of plates under UCSL Scope)						
	Fixing of Mild Steel Base plates, all as per the drawings, specification and directed by Engineer in charge. (350x25thk, 16mm dia Reinforcement Bent bar)						
	a) 25thk Plat					9900	KG



UDUPI COCHIN SHIPYARD LIMITED

Tender for Construction of Structural Foundation for Fixing of Rails
UCSL/CC/T/CIVIL/298 DT: 06TH NOVEMBER 2024

9 INSERT PLATES (Supply of plates under UCSL Scope)			
Fixing of Insert plates, All as per the drawings, specification and directed by Engineer in charge. (300x300x16thk, 4 No.s of ISA50x50x6 per IP, 300L)			
a) 16thk Plate		1700	KG
b) ISA50x50x6		800	KG
	TOTAL	12400	KG

7. ADDITIONAL WORK

- 7.1. This is a turnkey job and any additional work up to 5% growth of work in terms of total weight is to be envisaged and is to be undertaken without any additional price impact.
- 7.2. Any minor modifications, resulting from the change in statutory regulations prevailing at the time of final inspection of work to be carried out by the Contractor free of cost. In case of rework/modification/additional work, written consent is to be obtained from the officer in charge before the commencement of the work.
- 7.3. Contractor shall carry out the complete work in accordance with Shipyard's approved drawings. Any minor modifications from drawing or any other work or supply of material, which is not specified hereunder, but is considered incidental and essential for the successful completion of the job shall be carried out by the Contractor without any additional charge.
- 7.4. Contractor shall execute, during or after completion of the work, any minor job connected with the work, that is considered necessary by Shipyard.
- 7.5. The contractor shall be responsible for any damage caused to the material supplied by UCSL. Compensation with penalty for damage or loss of the item will be recovered from the Contractor, in the event of loss or damage.

8. VALIDITY

- 8.1. The offer shall be valid for a period of Six (06) months and no escalation in rate shall be allowed by UCSL on whatsoever reason.

9. SCHEDULE OF COMPLETION OF WORK:

- 9.1. Movable shed foundation construction is required to be handed over within 60 days duration from the date of issue of the Work Order.
- 9.2. Out of which construction of the entire foundation work must be completed within 45 days from the date of issue of purchase order. Remaining days shall be used only for curing.
- 9.3. The contractor must submit a detailed schedule of work with different stages of activities to UCSL before the commencement of work.

10. WORK PROGRESS AND SCHEDULE:

- 10.1. The construction of the sheds shall commence and be completed as per the schedule of completion indicated art clause no. 9 above.
- 10.2. The work is urgent and hence the contractor should start the work within 7 days from the issue of workorder.

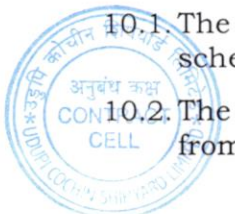

UDUPI COCHIN SHIPYARD LIMITED

Tender for Construction of Structural Foundation for Fixing of Rails
UCSL/CC/T/CIVIL/298 DT: 06TH NOVEMBER 2024

11. RATE:

11.1. Rates are to be quoted in the Price Bid Format at Annexure IV attached herewith.

12. PAYMENT TERMS:

12.1. Payment will be done in Three (03) stages:

STAGE-I:

20% of the total contract value against the supply & fixing of reinforcement steel as per the BOQ.

STAGE-II:

40% of the total contract value on successful completion of all the RCC casting works.

STAGE-III:

Final 40% of the total contract value on final handing over of the projects with necessary test certificates.

12.2. Payment shall be made within 30 days from the date of submission of bill and work completion certificate from the executing UCSL officer.

12.3. Invoice shall be submitted with necessary work completion certificate duly certified by UCSL representative on actuals.

12.4. Payment will be made by RTGS/NEFT to the account of Agency. The name of the bank, branch, A/C No., IFSC code & other particulars shall be furnished by the Agency in the proforma of UCSL.

13. TAXES & DUTIES

13.1. GST shall be applicable extra on the prescribed work. You are requested to furnish the following details in the invoice/Bill.

- Applicable rate of GST/SAC Code
- Firms GST Reg. NO.
- Service accounting code (SAC) as prescribed by statutory authorities.
- GST Reg. No. of Udupi Cochin Shipyard Limited(29AAACT1281B1ZO).

14. SECURITY DEPOSIT

14.1. The successful tenderer shall remit 5% of the value of the contract as security deposit within 15 days of receipt of the work order. This amount may be remitted by way of demand draft or bank guarantee (in approved proforma of UCSL) from any of the nationalized banks, valid till the satisfactory completion of the entire work. The Security Deposit will be released on certification of satisfactory completion of the contract and no liability to UCSL by Officer-in charge. The Security Deposit retained will not bear any interest.

15. PERFORMANCE GURANTEE

15.1. The complete work carried out by the contractor shall be guaranteed against defective on poor workmanship for a period of six months from the date of completion of work, whichever is earlier. Any work found defective during this period is to be repaired entirely at the contractor's cost and such repaired items shall be guaranteed for a further period of three months from the date of repair.

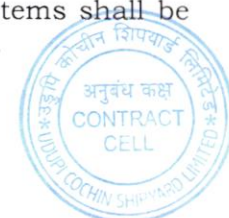



UDUPI COCHIN SHIPYARD LIMITED

Tender for Construction of Structural Foundation for Fixing of Rails
UCSL/CC/T/CIVIL/298 DT: 06TH NOVEMBER 2024

15.2. Should any unsatisfactory performance and / or damage or failure occur due to poor workmanship and poor-quality material used by the contractor, the contractor shall be solely responsible for payment/reimbursement of expenditure incurred by UCSL for rectifying the defect.

Towards this, a performance guarantee equivalent to 5% of the value of the contract to be furnished by the contractor on completion of the works by way of a bank guarantee (in approved proforma of UCSL) from a nationalized bank valid till the expiry of the guarantee period. In case the contract fails to submit the PG in time, SD mentioned at Clause 14 will be retained till the expiry of guarantee period.

16. LIQUIDATED DAMAGES

16.1. The progress of work will be monitored against the mutually agreed detailed schedule. Liquidated damages for delays in engagement of manpower as per the requirement, for any reason other than force majeure conditions, will be recovered at the rate of half percent of the value of the contract per week or part thereof, subject to a maximum of ten (10) percent of the value of the contract.

16.2. For better clarity, order values mentioned in LD clause are values excluding duties and taxes (Basic value). Liquidated damages, if any, shall be decided and settled only after the completion of the entire project but prior to the release of Final stage Payment.

16.3. If, for any reasons, supplier has a justification towards delay in supply / work execution and would intend to consider applicability/ non applicability of LD, the same shall be intimated to UCSL by way of a letter, failing which it will be deemed that delay is attributable to the supplier.

16.4. Delay in supply/Interruption of the work for reasons not attributable to supplier shall entitle extension of the order execution period for proportionate period without any additional cost to UCSL.

17. POWER OF ATTORNEY:

17.1. The tenderer(s) shall have to sign in each page of the tender documents with official stamp as a token of his acceptance of the conditions stated therein.

17.2. The person signing the tender form on behalf of another or on behalf of a firm, shall enclose to the tender, a Power of Attorney or the said deed duly executed in his favour or the partnership deed giving him such power showing that, he has the authority to bind such other persons or the firm, as the case may be, in all matters pertaining to the contracts. If the Person so signing the tender, fails to enclose the said Power of Attorney, his tender shall be liable for being summarily rejected. The Power of Attorney shall be signed by all partners in the case of partnership concern, by the Proprietor in the case of a proprietary concern, and by the person who by his signature can bind the company in the case of a Limited Company.

18. TERMINATION & LIMITATION OF LIABILITY:

18.1. This contract may be terminated upon the occurrence of any of the following events

18.2. By agreement in writing of the parties hereto;

18.3. By the non-defaulting party, upon default by the other party, of any clause of this contract, if not remedied within fifteen (15) days, or such longer time as may be agreed upon by the parties, after receipt of notice thereof in writing from the non-defaulting party;

18.4. By the other party, upon either party;





UDUPI COCHIN SHIPYARD LIMITED

Tender for Construction of Structural Foundation for Fixing of Rails
UCSL/CC/T/CIVIL/298 DT: 06TH NOVEMBER 2024

- i. Making the assignment for the benefit of creditors, being adjudged a bankrupt or becoming insolvent; or
 - ii. Having a reasonable petition filed seeking its' dissolution or liquidation, not stayed or dismissed within sixty (60) days; or
 - iii. Ceasing to do business for any reason.
- 18.5. For fraud and corruption or other unacceptable practices.
- 18.6. Upon expiry or termination of this Contract, neither party shall be discharged from any antecedent obligations or liabilities to the other party under this Contract unless otherwise agreed in writing.
- 18.7. UCSL may by notice in writing to Agency to terminate the order after issuing due notice i.e., 30 days' notice period. UCSL shall be entitled to compensation for loss limited to the order value.
- 18.8. Liability maximum that can be claimed by the Agency shall be limited to what is due to be and has been paid by UCSL for work done as per the payment milestones and limited to work order value.

19. ARBITRATION & JURISDICTION

- 19.1. Any disputes arising during the period of the contract shall, in the first instance be settled by mutual discussions and negotiations. The results of such resolution of dispute shall be incorporated as an amendment to the contract, failing which supplier shall approach the UCSL Grievance Redressal Committee as per relevant clause of the Contract.
- 19.2. If any dispute, disagreement or question arising out of or relating to or in consequence of the contract, or to its fulfillment, or the validity of enforcement thereof, cannot be settled mutually or the settlement of which is not herein specifically provided for, then the dispute shall within thirty days from the date either party informs the other in writing that such disputes, disagreement exists, be referred to arbitration. The arbitrators shall be appointed and the arbitration proceedings shall be conducted in accordance with and subject to the Arbitration and Conciliation Act, 1996 (No. 26 of 1996) as amended from time to time and the decision of the Arbitrators shall be final and binding on the parties hereto. The arbitration will be done by a Board comprising one arbitrator nominated by each party, and a mutually agreed Umpire. Each party shall bear its own cost of preparing and presenting its case. The cost of arbitration shall be shared equally by the parties unless the award provides otherwise. Performance under this Contract shall however, continue during arbitration proceedings and no payment due or payable by the parties hereto shall be withheld unless any such payment is or forms a part of the subject matter of arbitration proceedings.
- 19.3. Seat & Venue of Arbitration: The seat & venue of arbitration shall be at Bangalore.
- 19.4. Language of Arbitration: The Language of arbitration shall be English.
- 19.5. Governing Law: The contract shall be governed by Indian Law
- 19.6. In case of disputes, the same will be subjected to the jurisdiction of courts at Bangalore, Karnataka.

20. SUB CONTRACTING AND ASSIGNMENT:

- 20.1. Contractor shall not assign or transfer the Purchase Order/ Work Order or any share or interest therein in any manner or degree to any third party without the prior written consent of UCSL.
- 20.2. Contractor shall not contract with any subcontractor and/or vendor without the prior written consent of UCSL. Such consent shall not relieve the Contractor from any of his responsibilities and liabilities under the Purchase Order/ Work Order. In

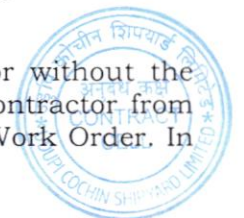



UDUPI COCHIN SHIPYARD LIMITED

Tender for Construction of Structural Foundation for Fixing of Rails
UCSL/CC/T/CIVIL/298 DT: 06TH NOVEMBER 2024

addition, Contractor shall ensure that the terms and conditions of any such contract shall comply with and correspond to the terms and conditions of the Purchase Order/ Work Order.

21. SECRECY & RESTRICTION ON INFORMATION TO MEDIA

- 21.1. The information contained in the enquiry as such shall NOT be communicated to any third party without prior approval of UCSL.
- 21.2. Information in respect of contracts/orders shall NOT be released to the national or international media or anyone not directly involved in its execution without the written approval of UCSL.

22. CANCELLATION OF ORDER AND RISK CONTRACTING

- 22.1. In the event the Agency fails to complete the work promptly and satisfactorily as per the terms of the order, and if any work is delayed beyond thirty (30) days from the agreed schedule, UCSL, without prejudice, reserves the right to cancel the order and get the work done at Agency's cost and the expenditure so incurred including any damage or loss will be recovered from him and the Security Deposit furnished by him is liable to be forfeited either in whole or in part.
- 22.2. UCSL also reserves to right to impose penalties ranging from Rs. 100 to Rs.500 to the employees of agencies and will be deducted from the bills, for any habitual offence on the cleanliness of uniforms, lack of obedience, not attending the tasks etc., and will be to the discretion of the Officer in charge for the work.

23. FORCE MAJEURE

- 23.1. Should failure in performance of any part of this contract arise from war, insurrection, restraint imposed by Government act or legislation of other statutory authority, from explosion, riot, legal lock-out, flood, fire, act of God or any inevitable or unforeseen event beyond human control which will be construed as a reasonable ground for extension of time, UCSL may allow such additional time as is mutually agreed to be justified by the circumstances of the case.

24. IMS GUIDELINES

- 24.1. UCSL implemented an Integrated Management System (IMS) and the Quality Management System (QMS) within the yard. As part of IMS, subcontractors shall comply with the following measures related to the Quality, Health, and Safety & Environment (QHSE) policy of UCSL.
- a) Meeting or exceeding customer requirements.
 - b) Assuring quality of the products and service.
 - c) Preventing occupational ill health & injuries.
 - d) Ensuring safe work sites.
 - e) Conserving natural resources.
 - f) Preventing / minimizing air, water & land pollution.
 - g) Handling and disposal of Hazardous wastes safely.
 - h) Complying with statutory & regulatory and other requirements.
 - i) Developing skills and motivating employees.
- 24.2. Occupational Health, safety & Environmental requirements of UCSL shall also include the following.
- a) The contractor (or a sub-contractor performing work on behalf of the contractor) is deemed to comply with the Occupational health, safety and environmental policy of the company and also to all operational controls/standard operating procedures and shall undertake the work in total compliance with the





UDUPI COCHIN SHIPYARD LIMITED

Tender for Construction of Structural Foundation for Fixing of Rails
UCSL/CC/T/CIVIL/298 DT: 06TH NOVEMBER 2024

- requirements of the established Integrated Management System (IMS) of the company.
- b) The Contractor shall undertake the work in total compliance with all applicable legal/statutory requirements related to occupational health, safety and environment effective in the state of Karnataka.
 - c) It is the sole responsibility of the contractor to assure that any sub-contractor/s who shall perform works in company lands/facilities/worksites on behalf of the contractor, is also following all requirements related to the Integrated Management System of the company and the health/safety/environmental Rules effective in the state.
 - d) The contractor shall provide/implement and operate/practice all occupational health, safety and environmental management measures/facilities, for their period of contract, in their activities/at their work sites, which shall be required according to the IMS of the company or that required by the health/safety/environmental Rules established and effective in the state, at their own cost.
 - e) If any contractor failed to comply with or violated any clauses/requirements of occupational health, safety and environmental Rules effective in the state, in their activities or at work sites and the same shall be exposed to the government or any competent authorities upon inspections, the contractor shall be solely responsible for all liabilities caused by his/her action and shall be responsible for paying the penalty and taking stipulated corrective actions insisted by the authorities within the specified time, at their own cost. Any liability to the company in this regard needs to be compensated by the contractor.
 - f) Upon completion of the work, contractor shall clear the area and shall not leave any Occupational health/safety/environmental liabilities to the company, from their activities at the worksites.
 - g) Any clarification related to IMS requirements of the yard, may be obtained by the contractor from the AGM (HSE) or the authorized representative of the contract, prior to the commencement of work.

25. SAFETY OF PERSONNEL AND FIRST AID

- 25.1. The contractor shall be entirely responsible for the safety of all the personnel employed by him on the work. In this regard, he may adopt all the required safety measures and strictly comply with the safety regulations in force. A copy of UCSL's "Safety Rules for Contractors (Revised)" is available with HSE department for reference.
- 25.2. The Agency may arrange to suitably insure all his workmen/ other personnel in this regard. UCSL will not be responsible for any injury or illness to the Agency's workmen/other personnel during execution of the works due to whatsoever reasons.
- 25.3. In this regard, the Contractor will have to fully indemnify UCSL against any claims made by his workmen/other personnel
- 25.4. The Agency shall provide and maintain so as to be readily accessible during all working hours, a first aid box with prescribed contents at every place where he employs contract labor for executing the works.





UDUPI COCHIN SHIPYARD LIMITED

Tender for Construction of Structural Foundation for Fixing of Rails
UCSL/CC/T/CIVIL/298 DT: 06TH NOVEMBER 2024

26. LABOUR LAWS AND REGULATIONS

- 26.1. The Agency shall undertake and execute the work with contract Labor only after taking license from the appropriate authority under the Contract Labor (Regulation & Abolition) Act 1970.
- 26.2. The Agency shall observe and comply with the provisions of all labour and industrial laws and enactments and shall comply with and implement the provisions of the Factories Act, 1948, Employees Provident Funds & Miscellaneous Provisions Act, 1952, Employees State Insurance Act, Payment of Gratuity Act, minimum Wages Act, Payment of Bonus Act, Contract Labour (Regulation and Abolition) Act and all other enactments as are applicable to him and his workmen employed by him. The Agency shall inform UCSL his license number from the Central Labour Commissioner.
- 26.3. All Persons, except those exempted under the respective Acts, shall necessarily be insured under the ESI scheme and be made members of the EPF Scheme from the day of their engagement as personnel in the Company. In Case 1, All such insured Persons should carry with them their ESI Identity Card for verification by the authorities. No Persons without a valid ESI Identity Card for verification by the authorities will be permitted to work in the company.
- 26.4. The Agency shall submit the Labour Reports>Returns as required by the Company from time to time in respect of their workmen in standard format to the concerned contracting officer so as to enable the same to reach Contract cell by the 5th of every month. Delayed submission of the same shall attract penal interest /damages at the rate as levied by the respective authorities under the relevant Acts.
- 26.5. The Agency shall maintain the records viz. Muster Roll, Acquittance Roll with full details, Account books etc., in original. These are required for inspection by the concerned authorities under each scheme.
- 26.6. If the Agency fails to pay any contributions, charges or other amounts payable under any of the aforementioned provisions of law, UCSL shall deduct or adjust amounts equivalent to such contribution, charges or amounts from amount payable to him by UCSL, including any deposit or amounts payable against bills and make payments on his account to the appropriate authority. He shall not be entitled to question or challenge such deductions, adjustments or payment made by UCSL.
- 26.7. Any other amount payable under any law or in respect of any person employed by the Agency, if not paid by him, shall be deducted or adjusted by UCSL out of any amount payable to the Agency including any Security Receipt and paid ever or withheld for payment by UCSL.
- 26.8. The Agency shall be fully responsible for the conduct and discipline of the workmen employed by him in the Company premises. If such workmen commit any misconduct or criminal act inside the Company, the Agency shall take appropriate action against such workmen. The Agency shall abide by the instructions/ guidelines issued by the Company for maintenance of discipline and good conduct among the workmen employed by him.
- 26.9. All persons who are engaged for various works in UCSL either directly or through Agency/contractors, should produce the following documents prior to issuing their entry passes:





UDUPI COCHIN SHIPYARD LIMITED

Tender for Construction of Structural Foundation for Fixing of Rails
UCSL/CC/T/CIVIL/298 DT: 06TH NOVEMBER 2024

26.10. Passport/Aadhaar attested copy of passport with photo and address particulars.

OR

Police clearance certificate with photo and address particulars. (Police clearance certificate to the effect that the concerned person is staying in the area of jurisdiction of the certificate issuing Police Station and that the person is not involved in any criminal offences as per the records available therein.)

26.11. Application and Declaration for enrolling under Employees Provident Fund and ESI Scheme- 3 individual passport size photographs and two copies of family photographs of the members.

26.12. **Agency shall familiarize themselves with the labour rules & regulations.**

27. OVERWRITING & CORRECTIONS

27.1. Tenders shall be free from overwriting or erasures. Corrections and additions, if any, shall be duly attested and a separate list of such corrections shall be attached with the offer.

28. OTHER TERMS & CONDITIONS

28.1. Quality of services shall conform to the specification/ standards laid down by UCSL.

28.2. UCSL reserves the right to accept / reject any offer.

28.3. During the evaluation of tender, officer-in-charge may seek clarifications from the bidders. Clarification if any shall be given in writing/e-mail. Officer-in-charge's decision will be final and binding on the bidder.

28.4. Compliance of all statutory safety requirements and other safety rules stipulated by UCSL and other applicable statutory bodies shall be the responsibility of the Agency while working at UCSL premises. The Agency should ensure that their workmen and staff are adequately covered under Insurance.

28.5. Damages caused to the Shipyard properties/tools/accessories should be rectified by the Agency at his cost or proportional recoveries will be made from the Agency while passing their bills for payment.

28.6. The service provider shall have to engage men on round the clock basis and also on Sundays and holidays. Service has to be completed to the satisfaction of Udupi Cochin Shipyard Limited officer in-charge.

28.7. The service provider shall indemnify UCSL or its officers against any claims arising out of accidents or injuries to workmen or other persons or damage to other property which may arise during the execution of the contract or from breach of any Law or Regulation prior to delivery and acceptance of the items at UCSL.

28.8. The service provider shall also be governed by the General Conditions of Contract of UCSL, General Safety Rules and other relevant labour laws.

28.9. The upper age limit of all workers and supervisors employed by the Agency and those Agency who do or supervise the job themselves shall be as per the prevailing rules of UCSL and shall comply to the requirements of this tender.

28.10. Assistant General Manager, or his authorized representative will be the Officer-in-charge of these contracts.



POWER OF ATTORNEY

(On Applicant's letter head)

(Date and Reference)

To
The Assistant General Manager (Materials & Contract Cell)
Udupi Cochin Shipyard Limited
Fishing Harbour complex, Malpe,
Udupi - 576 108.

Subject: Power of Attorney

Mr. / Mrs. / Ms..... (Name of the Person(s)),
domiciled at.....(Address), acting as..... (Designation and name of the company), and whose signature is attested below, is hereby appointed as the Authorized Representative and authorized on behalf of..... (Name of the company) to provide information and respond to enquiries etc. as may be required by the Employer for the project of (Project title) and is hereby further authorized to sign and file relevant documents in respect of the above.

(Attested signature of Mr.)

For.....
(Name & designation)

(Company Seal)



UNCONDITIONAL ACCEPTANCE LETTER

(Unconditional acceptance to be given by in letter head)

ACCEPTANCE OF TENDER CONDITIONS

1. Tender Document no. UCSSL/CC/T/CIVIL/298 dated 06th November 2024 Tender for Construction of Structural Foundation for Fixing of Rails, has been received by me/us and I/We hereby unconditionally accept the tender conditions of tender documents in its entirety for the above work.
2. It is further noted that it is not permissible to put any remarks/conditions in the tender enclosed in "Part-2 (price bid)". I/We agree that the tender shall be rejected and ACCEPTING AUTHORITY.

Yours faithfully,

(Signature of the tenderer) with rubber stamp

Date:



UDUPI COCHIN SHIPYARD LIMITED

Tender for Construction of Structural Foundation for Fixing of Rails
UCSL/CC/T/CIVIL/298 DT: 06TH NOVEMBER 2024

UCSL/CC/T/CIVIL/298 DT: 06TH NOVEMBER 2024
**TENDER FOR CONSTRUCTION OF STRUCTURAL FOUNDATION OF FIXING
OF RAILS**
PRICE BID FORMAT

Sl. No.	Description	Unit	Quantity	Rate	Total Amount
1	RCC Floor Chipping Works	M3	45		
2	Earthwork in excavation for foundation	M3	280		
3	Earthwork in soil backfilling	M3	70		
4	Boulder stone soling 230mm thick	M3	70		
5	Providing & Laying PCC Bed in M15	M3	30		
6	Providing & laying RCC in M30	M3	150		
7	Supply & Fixing FE-550 TMT reinforcement	KG	14500		
8	Fixing of MS base Plates, insert Plates	KG	13000		
9	Total:				
10	CGST/SGST.....%				
11	Grand Total Amount:				
Grand total in words-					

- L1 will be determined based on the serial no.09

Signature:

Date:

Address of the contractor:

Seal:





UDUPI COCHIN SHIPYARD LIMITED
Tender for Construction of Structural Foundation for Fixing of Rails
UCSL/CC/T/CIVIL/298 DT: 06TH NOVEMBER 2024

ANNEXURE-V

TECHNO COMMERCIAL CHECK LIST (To be submitted by the bidder)

(Bidders may confirm acceptance of the Tender Conditions/deviations if any to be specified)

SL No.	Tender Enquiry Requirements	Confirmation from bidder (Strike off whichever is not applicable)	Specific comments /Remarks
1	Terms & Condition, Scope of work & Indicative Quantum of Work. (Annexure-I)	Agreed as per tender /Do not agree	
2	Schedule of Completion as per clause no 9	Agreed as per tender/Do not agree	
3	Unconditional Acceptance	Agreed as per tender/Do not agree	
4	Offer Validity	06 Months - Agreed as per tender/Do not agree	
5	Taxes & Duties	Specified/included in Price	
6	Payment terms - confirm		
a	As per Clause 12 of Annexure - I	Agreed as per tender/Do not agree	
7	Security Deposit	Agreed as per tender/Do not agree	
8	Performance Guarantee	Agreed as per tender/Do not agree	
9	Force Majeure	Agreed as per tender/Do not agree	
10	Liquidated damages and cancellation of contract	Agreed as per tender/Do not agree	
11	Arbitration & Jurisdiction clauses	Agreed as per tender/Do not agree	
12	Confirm all other terms and conditions of our enquiry are acceptable.	Confirmed/Not confirmed	
13	Deviations from Tender conditions	No Deviations	

Signature:

Address of the Contractor:

Seal:



00R3V310S9L70SR

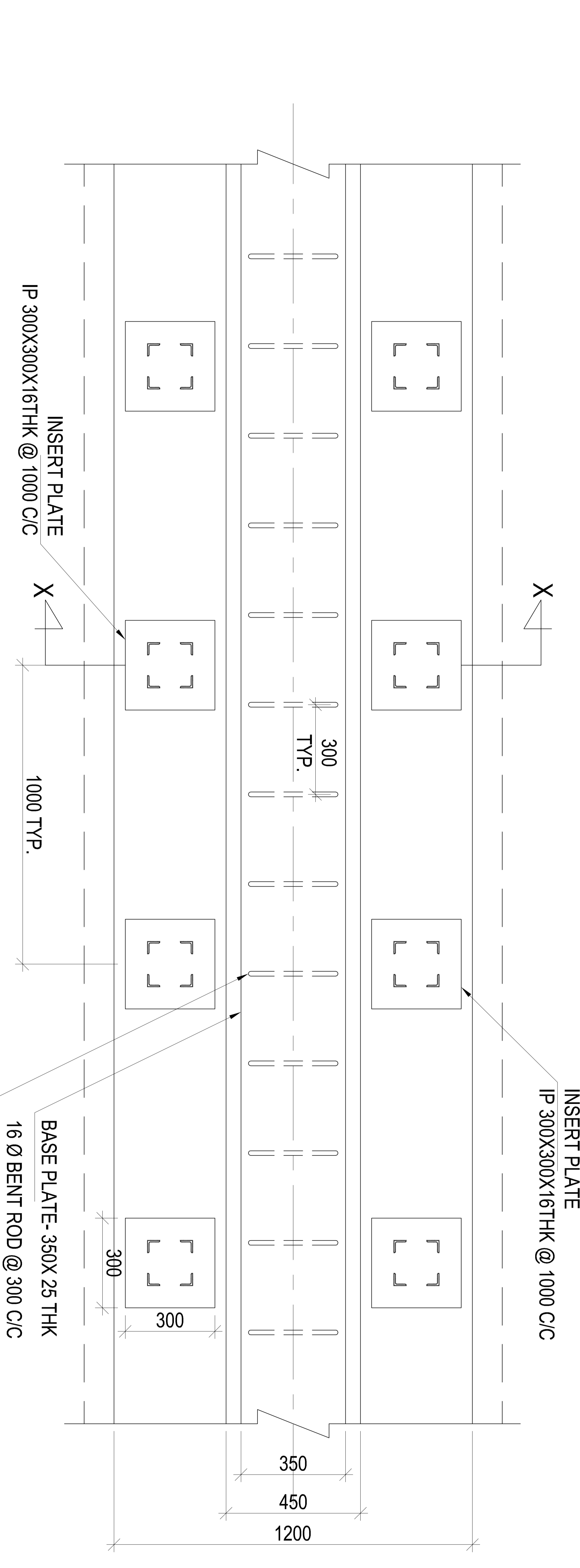

PLAN

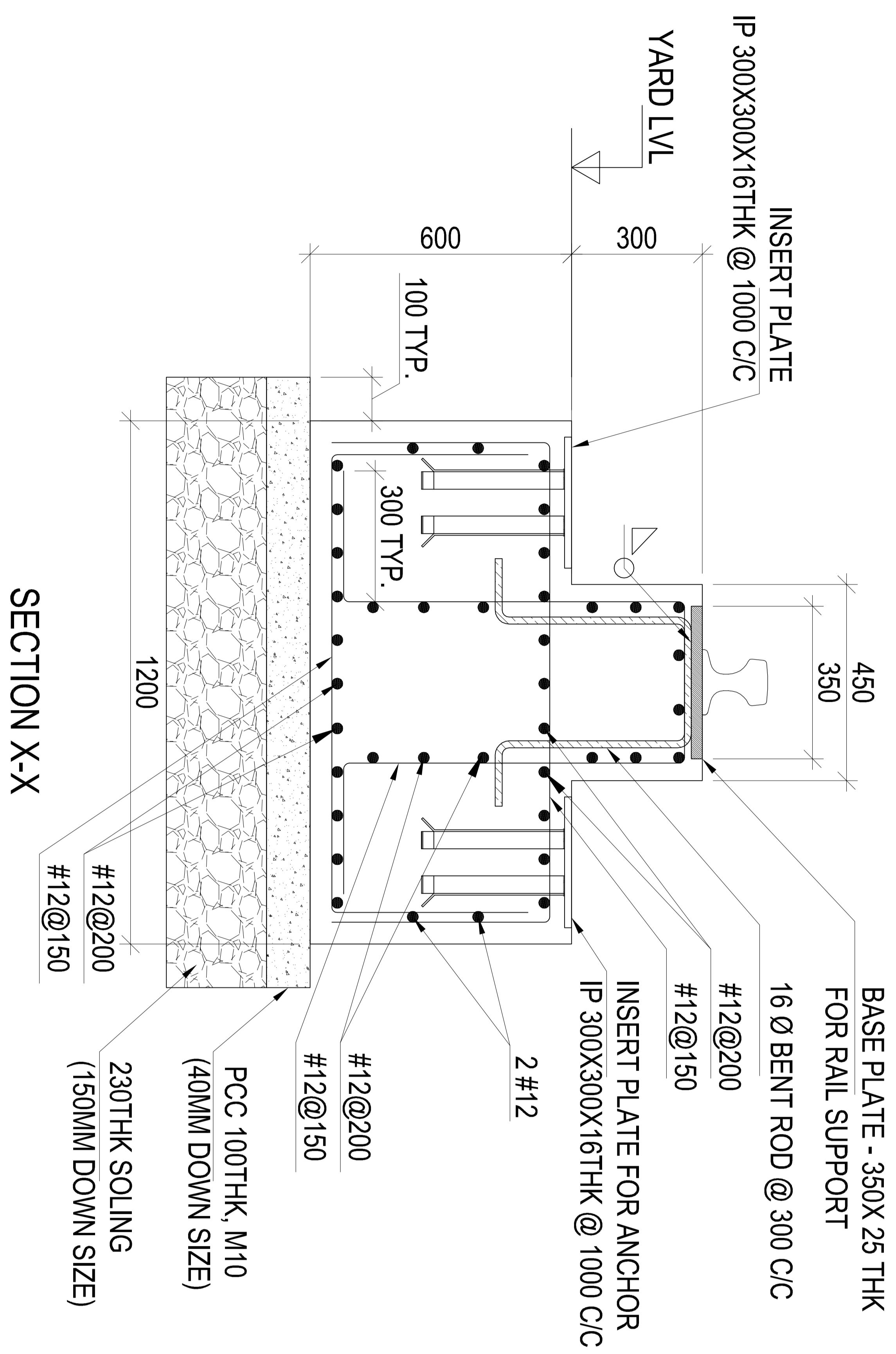

SECTION X-X

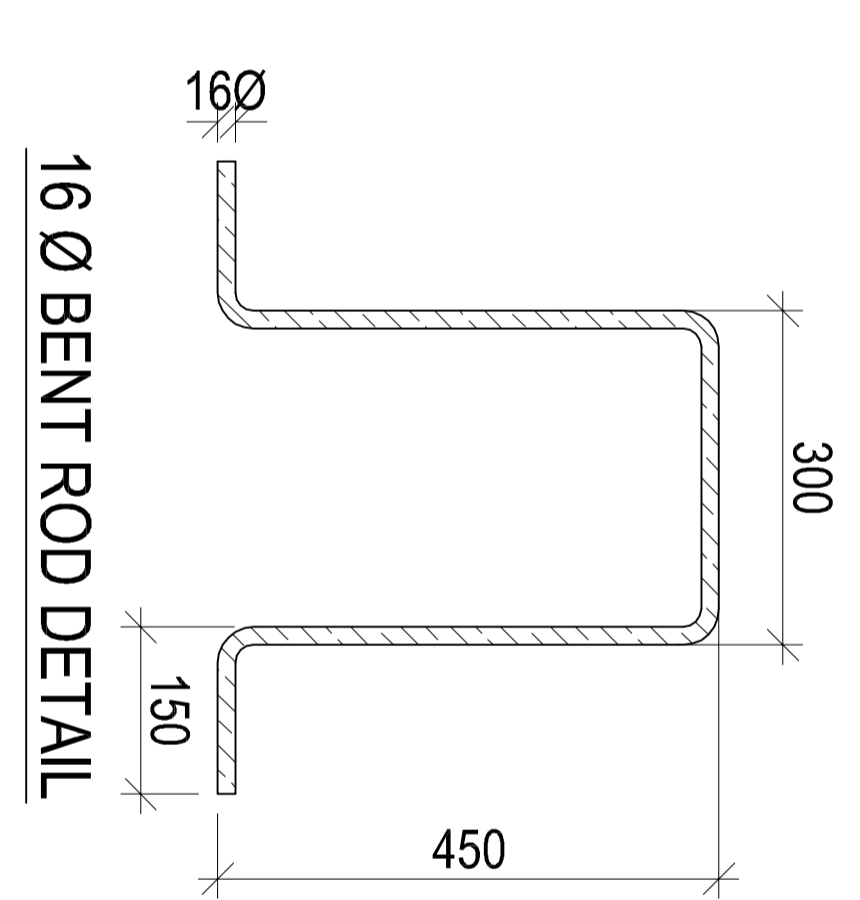

16 Ø BENT ROD DETAIL

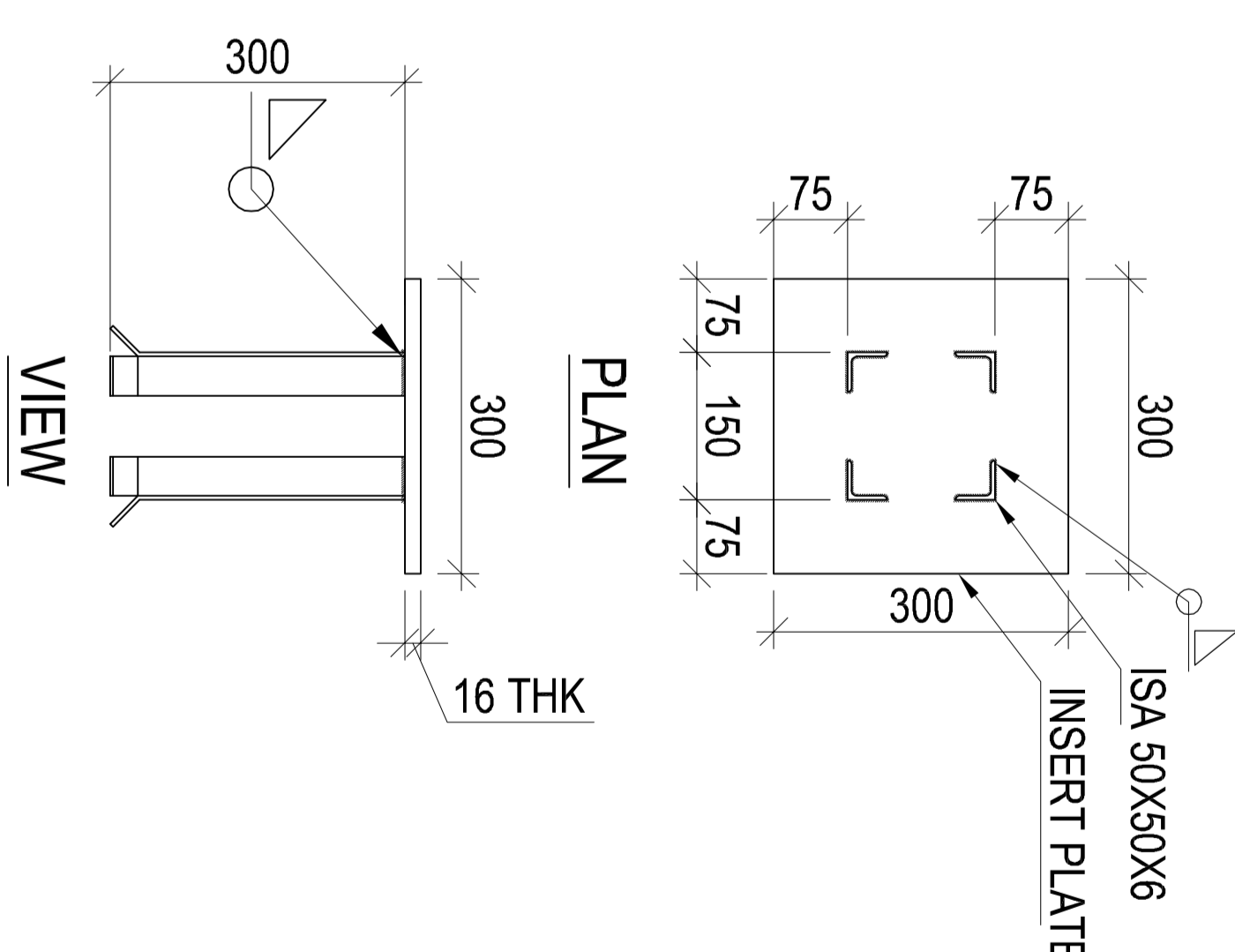

INSERT PLATE DETAIL
IP -300X300X16 @1000 C/C

THIS DRAWING AND THE DESIGN IT COVERS ARE THE PROPERTY OF ROY & SHENOY. THEY ARE MERELY LOANED AND ON THE BORROWERS EXPRESS AGREEMENT THAT THEY WILL BE USED FOR THE BUILDING/ STRUCTURE / LOCATION COVERED UNDER SPECIFIC WORK ORDER. THEY WILL NOT BE USED FOR ANY OTHER PURPOSE NOR FOR THE SIMILAR STRUCTURE AT ANY OTHER LOCATION & SHOULD NOT BE ISSUED TO ANY THIRD PARTY IN WHOLE OR IN PARTS. THEY WILL NOT BE REPRODUCED, COPIED, LOANED, EXHIBITED, NOR USED EXCEPT IN THE LIMITED WAY AND PRIVATE USE PERMITTED BY ANY CONSENT GIVEN BY THE LENDER TO THE BORROWER.

- NOTE:
1. ALL DIMENSIONS ARE IN MILLIMETER.
 2. THIS DRG. IS NOT TO ANY SCALE FOLLOW WRITTEN VALUES ONLY. DO NOT SCALE THE DRG.
 3. THIS DRAWING SHALL BE READ IN CONJUNCTION WITH RELEVANT ARCHITECTURAL, PLUMBING, ELECTRICAL OR OTHER RELATED DRAWINGS.
 4. USE **M30** GRADE CONCRETE
 5. CLEAR COVER TO MAIN REINFORCEMENT IN FOOTING 50MM, PEDESTAL 40MM, BEAM 25MM.

6. LAP LENGTHS SHOULD BE 50% OF BAR.
7. DEVELOPMENT LENGTHS FOR REINF. ARE 32Ø - 1600MM, 25Ø - 1250MM, 20Ø - 1000MM, 16Ø - 800MM, 12Ø - 600MM
8. TMT BARS **FE 550** GRADE WITH ELONGATION MORE THAN 14.5% OR **FE 550D** AS PER IS 1786-2008. USED AS REINFORCEMENT STEEL

REV.	DATE	DESCRIPTION	SIGNATURE	UPDATED RECORDS

CLIENT	UDUPI COCHIN SHIPYARD LIMITED Malpe Harbour Complex, Malpe Udupi 5761 08
STRUCTURAL CONSULTANT	Roy & Shenoy An ISO 9001 Certified Company ARCHITECTURE, STRUCTURAL ENGINEERING AND PROJECT MANAGEMENT Third Floor, CRISTAL, APC, Bellaria Road, Hampdena, Mangalore-57501, Ph:91-824-244331, 244332

PROJECT	MOVABLE COVERED SHED AT UCSL MALPE YARD
TITLE	RAIL SUPPORT DETAILS
DRAWN	NAVEEN
SCALE	NOT TO SCALE
DRAWING NO.	R S O 7 7 6 S O 1 3 A 3 R 0 0
CHECKED	ROHITH
APPROVED	P. SHENOY
DATE	27-09-2024
JOB NO.	0776